

## Development of Micro Solar-Hydro Power Generation System for Rural Area Under Tropical Climate

(Pembangunan Sistem Penjanaan Tenaga Mikro Solar-Hidro untuk  
Kawasan Pendalaman Cuaca Tropikal)

WONG SIE WOO, \*SYLVIA ONG AI LING, LIM CHE CHIEN, PETRUS JULINI GOEL  
Department Of Electrical Engineering, Politeknik Kuching Malaysia

### Abstract

Energy is required in this day and age, more than ever as a result of modernization, industrial development, and population growth to meet the demand of urban life. However, the power supply distribution system poses a significant challenge in rural or remote areas, as the area are geographically isolated from the grid connection. Thus, it is a necessity to shift the use of conventional energy sources to renewable and green technology resources such as solar, wind, hydro, and others as an alternative for rural electrification. The goal of this project is to create a standalone hybrid micro solar-hydro power generation system specifically designed for small communities in rural areas. This project focuses on the combination of an 18V/100 Watt solar panel, 12V micro-hydro generator, DC-AC inverter, and 12V 20Ah deep cycle battery for sustained power generation. As this system implements solar and hydro resources: an auto photo switch on-off photocell is integrated into the system for switching purposes. The project is designed to support a community, because of an average household load demand such as lighting, television, and fans that requires 2.24kW/day. This project offers a significant and promising method for effective utilization of the abundant solar and hydro resources nearby the rural area.

Keywords: Renewable energy system, hybrid, micro solar-hydro power generation system, standalone system

**Received:** August 01, 2021; **Accepted:** September 26, 2021; **Published:** November 21, 2021

© 2021 PKS. All rights reserved.

\* Corresponding author: sylvia\_ong@poliku.edu.my

## INTRODUCTION

Electrical power generation capacity is an important driving force of a country's growth, particularly in socioeconomic. Due to the exponential growth of energy demand and the reduction of fossil fuels, rigorous attention needs to be studied for electrification from renewable energy sources. This is not just necessary for urban areas but especially rural areas as the areas face significant challenge in the power supply distribution system due to the geographically isolation with low population and constrained transmission from the grid connection (Imeshqab & Ustun, 2019, Shrestha et al., 2019). There are many renewable energy sources such as solar, wind, hydro and others have been discovered, studied and implemented for electrification (Kanoğlu et al., 2020). Solar, wind and hydro energy are the most abundant renewable energy sources as compared to the combustion of fossil fuels like coal and gas. This is because the renewable energy are extremely clean, sustainable, and has major environmental benefits (i.e. environmental protection and air quality improvement) especially in tropical region whereby the resources are accessible all over the year.

Because of the abundance of renewable resources, micro hybrid power systems have become a popular trend in the design of electrical power generation systems. The hybrid system which combines several energy resources is an independent technology offers several benefits over the single system. Studies suggest that combining solar and wind energy has the ability to deliver reliable power at cheap prices while not disrupting the natural balance (Sterl et al., 2018, Khalid et al., 2018, Jenkins et al., 2019). The system consists of the integration of a dual-energy system that will provide stable power. Photovoltaic (PV) technology is a type of solar energy conversion system that uses the sun's energy to generate electricity employing a solar module. The solar module is made up of many solar cells which are wired together and encased in plastic and glass with a metal frame. An inverter is a component of a PV system that converts direct current electricity generated by solar cells into alternating-current electricity. Solar electric systems are ideal for isolated locations where laying power lines would be prohibitively expensive. Wind turbines, on the other hand are used to convert wind energy into electricity. The article discusses the cases of power generation using two sources, which leads to the obstetrics of electricity at affordable prices with higher reliability to cater the electricity demand especially in rural area.

Apart from integrating solar and wind energy, another energy resource - hydro power systems can be utilized to convert the potential energy in a small streams and waterways into kinetic energy via mechanical turbine, then the power is converted into electricity using an electric generator or is used directly to run milling machines (Yah et al., 2017). Hydropower technology has been with us for more than a century.

To overcome the electricity shortage, villagers in Malaysia, particularly in rural areas, continue to use non-eco-friendly and expensive fuels such as petrol and diesel for generators. Furthermore, due to its location in areas with slower wind speeds, Malaysia faces numerous challenges in the development of wind energy in the South East Asia region. Malaysia, on the other hand, has an abundance of rivers that allow for the implementation of hydropower generation. Thus, it is of the researchers' interest to develop an eco-friendly micro solar-hydro power electrification system for the rural areas in a tropical climate environment using the renewable natural resources to generate electricity continuously.

The objectives of this project are to:

- (a) Develop a hybrid renewable energy system to cater the demand from the rural areas.
- (b) Build a combination of micro solar-hydro system as well as to charge a 12V 4AH

battery that leads to an uninterrupted power supply to cater the demand from the rural areas.

### SYSTEM DEVELOPMENT

This project includes two types of distributed generators: a synchronous generator that generates power in the hydro system and an inverter-based system that generates power in the photovoltaic system. Both types of generator constituents have distinct properties. Inverters are solid-state electronic devices that convert Direct Current (DC) power to Alternating Current (AC). The block diagram of the micro solar-hydro power generation system is presented in Figure 3.1.

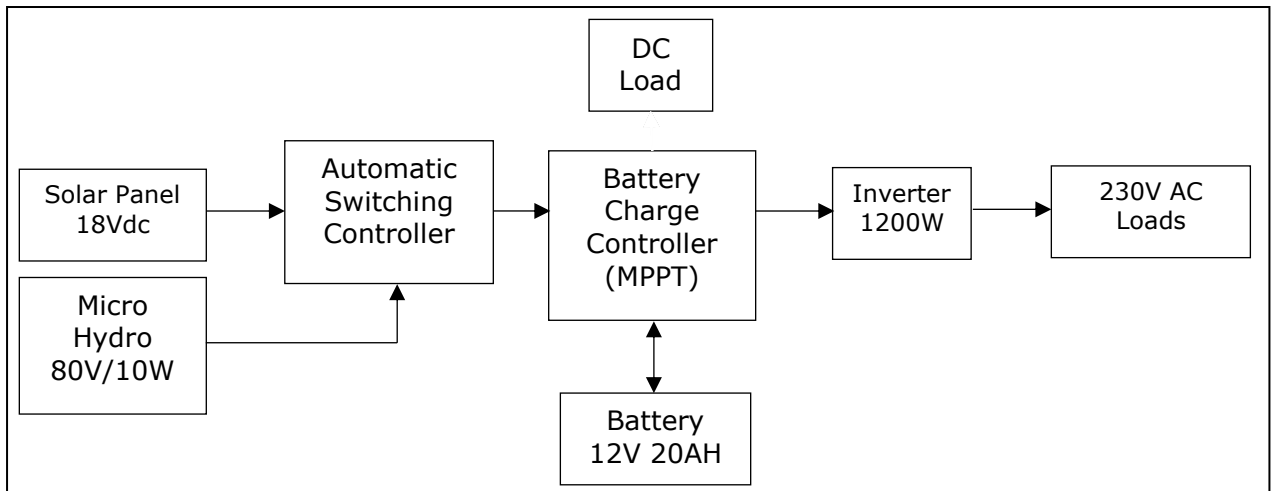

Figure 3.1 Block Diagram of Micro Solar-Hydro Power Generation System

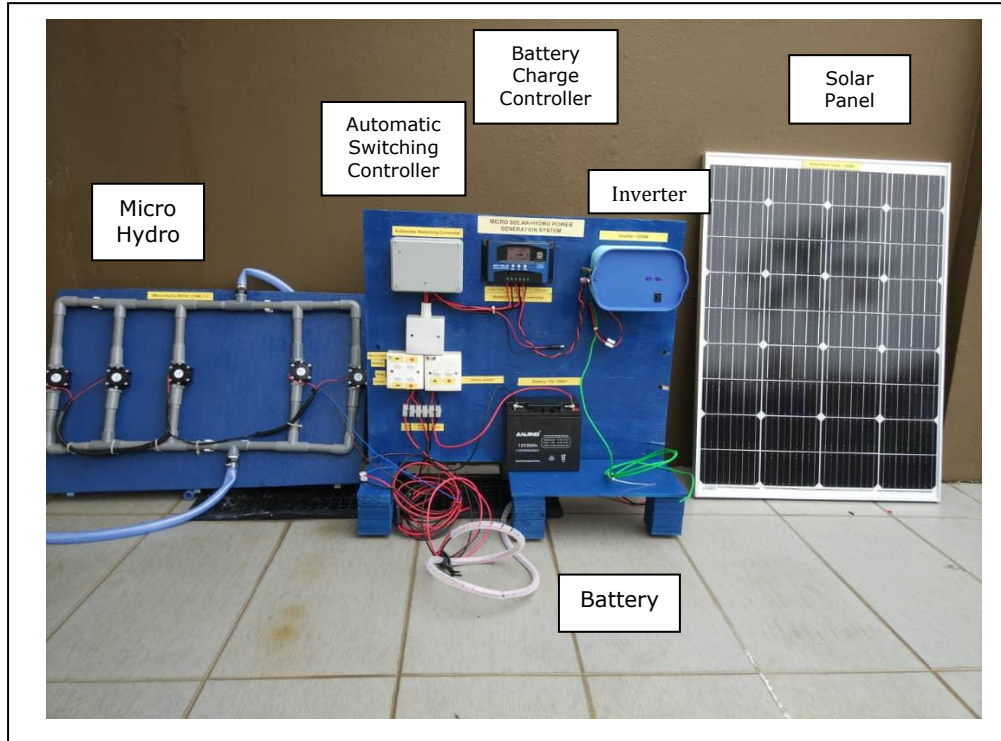

Figure 3.2 The Prototype of Micro Solar-Hydro Power Generation System

During the day, a monocrystalline solar panel (18v/100watt/5.6A) serves as the primary power source. Solar panels act as the medium to convert solar energy into the electrical energy through the process called photo electric effect. The panels are built with

photovoltaic cells whereby sun rays are absorbed with this material to generate current. This panel conducts electricity more efficiently and performs better in high light intensity and shaded environments, allowing it to generate more solar power. On the contrary, micro hydro (12V DC) is used as the main power supply particularly during night and rainy days. By using the natural flow of water, it can generate 10-20 watts and up to 12 Volts of electricity. This micro hydro 12V is powerful and sufficient to power domestic LED bulbs or tubes as well as to charge a 12V 20AH battery. The amount of energy provided by micro hydro turbines is determined by the velocity of the water flowing through the turbine. During rainy seasons, the influence of sun at the site is reduced, thus a hybrid solar system is more likely to be used. Both solar and micro hydro system are hybridized using an automatic switching controller. The automatic switching controls are based on the light sensor concept by which the switching controls are switched to solar panels when the sensor senses light during the day. In contrast, the switching control is switched to the micro-hydro when the day is cloudy, raining or at night. Therefore, the solar panel and micro hydro always supplies the solar battery with current.

The power output from the switching controller is fed into the solar charge controller with an appropriate capacity to charge the batteries. Solar charge controller is used to manage the power going into the battery bank from the solar panel. It ensures that the deep cycle batteries are not overcharged during the day. Additionally, it provides reverse current protection to the solar panel and prevent the batteries from drainage. An inverter is then used to convert the DC power in the solar battery to AC power, which is fed to the predetermined loads such as the Light Emitting Diode (LED) lamps, fan, television, mobile charger and other household appliances in the rural areas. This configuration is simple and economical to implement. The energy produced by the solar panel and the micro hydro are then stored in the solar battery. By connecting the batteries in serial or parallel, any necessary capacity can be obtained.

## RESULTS AND DISCUSSION

The solar panel was tested different times throughout the day in the month of May 2021. Figure 4.1 shows the open-circuit voltage test versus time of the day to verify the functionality of the panel. Also, the five micro-hydro connected in parallel were tested and were able to produce average voltage of 16V to 18V depending on the flow of the water. The output voltage from the micro solar-hydro system was significantly enough to charge a 12V battery from both renewable sources.

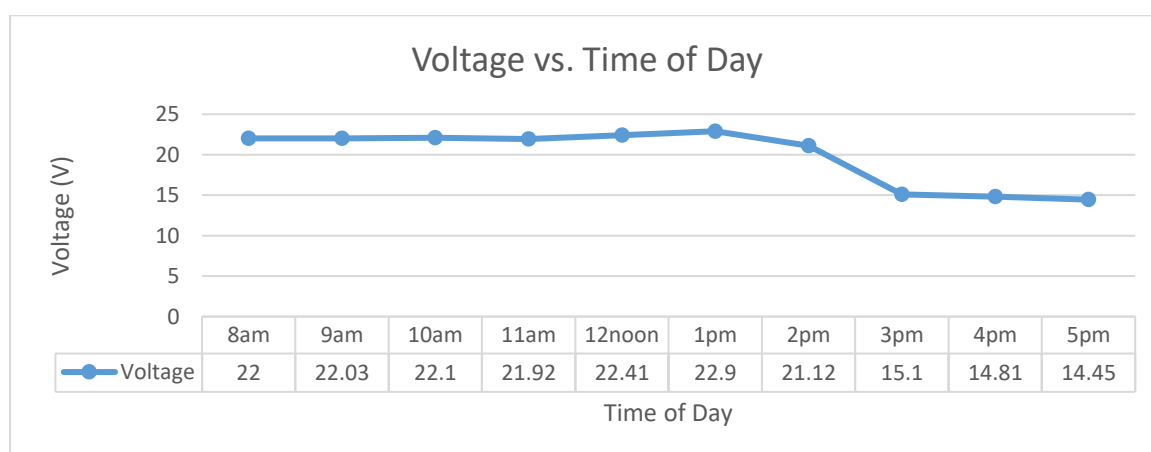

Figure 4.1 Open-circuit Voltage Test versus Day Time

Then, a battery was connected to the system and left to charge for the whole day. The battery output voltage was measured the following day while they were connected to the solar panel, micro hydro and charge controller. The measured battery output voltage was

estimated to be 12V. After the individual system parts were successfully checked and tested, the device was connected to the multiple loads of a household.

For a typical daily electricity consumption of a household in Sarawak rural area, five LED lamps, 12W of power each, were equipped to a household. The use of lamps other than Compact Fluorescent Lamps (CFLs) and light bulbs was strictly restricted in order to minimize energy consumption.

Table 4.1: Typical daily electricity demand of a village house in rural area.

Loads	Unit	Power (Watts)	Hours	Energy/day (kWh)
LED lamps	5	60	6	0.360
Television 50"	1	100	6	0.600
Fan/Ceiling Fan	1	100	8	0.800
Mobile charger	1	10	2	0.020
Radio	1	50	2	0.100
Computer	1	250	3	0.750
			Total	2.630

Table 4.1 sums up the demand generated by the increased consumption of electricity from basic lighting to a moderate domestic use by households in a rural area of Sarawak where on-grid power transmission is unavailable. A load profile was estimated based on data on electricity consumption and their duration during the day. Electricity is estimated to be 2.63 kWh per day in a household. By hybridizing both sources, it helps to increase the energy supply reliability and meet the demand. It also ensures that the storage device is charged with sufficient extra power over peak hours.

The lighting system and other multiple loads were connected to the 240V AC and 12V DC output, and the results demonstrated the hybrid controller's ability to power both AC and DC loads in the household. The hybrid power controller demonstrated its complete versatility to combine DC and AC sources to power up the house, along with all the connections and voltage across the house all working as desired. In addition, the 20Ah battery was able to last for 1.75 day for a household with energy consumption of 2.63kWh.

## CONCLUSION

This project presents the development of a micro solar-hydro power generation system for rural areas, particularly in tropical environment. The project provides a significant power supply generation for residential electrical system in villages that is powered by solar and hydro, both of which are natural renewable resources. This system is intended to provide electricity for off-grid applications where the national utility grid is not economical. Integrating distributed generating systems increased the reliability and quality of the power. By reducing the demand for fossil fuels and wood, the use and hybridization of available abundant solar and hydro resources nearby the rural areas promotes environmental sustainability. Furthermore, it will help to promote more productive and healthy lifestyles.

## ACKNOWLEDGEMENT

The authors would like to thank Howard Kuruk Anak Henrix, Remmyson Empading Anak Geyong and Kenneth Atai anak Nicholas for providing the necessary support to conduct this project.

## REFERENCES

- Almeshqab, F., & Ustun, T. S. (2019). Lessons learned from rural electrification initiatives in developing countries: Insights for technical, social, financial and public policy aspects. *Renewable and Sustainable Energy Reviews*, 102, 35-53.
- Jenkins, P., Elmnifi, M., Younis, A., & Emhamed, A. (2019). Hybrid Power Generation by Using Solar and Wind Energy: Case Study. *World Journal of Mechanics*, 9(4), 81-93.
- Kanoğlu, M., Çengel, Y. A., & Cimbala, J. M. (2020). *Fundamentals and applications of renewable energy*. McGraw-Hill Education.
- Khalid, M., AlMuhaini, M., Aguilera, R. P., & Savkin, A. V. (2018). Method for planning a wind-solar-battery hybrid power plant with optimal generation-demand matching. *IET Renewable Power Generation*, 12(15), 1800-1806.
- Shrestha, A., Bishwokarma, R., Chapagain, A., Banjara, S., Aryal, S., Mali, B. & Korba, P. (2019). Peer-to-peer energy trading in micro/mini-grids for local energy communities: A review and case study of Nepal. *IEEE Access*, 7, 131911-131928.
- Sterl, S., Liersch, S., Koch, H., Van Lipzig, N. P., & Thiery, W. (2018). A new approach for assessing synergies of solar and wind power: implications for West Africa. *Environmental Research Letters*, 13(9), 094009.
- Yah, N. F., Oumer, A. N., & Idris, M. S. (2017). Small scale hydro-power as a source of renewable energy in Malaysia: A review. *Renewable and Sustainable Energy Reviews*, 72, 228-239.